

Negative Air Systems™

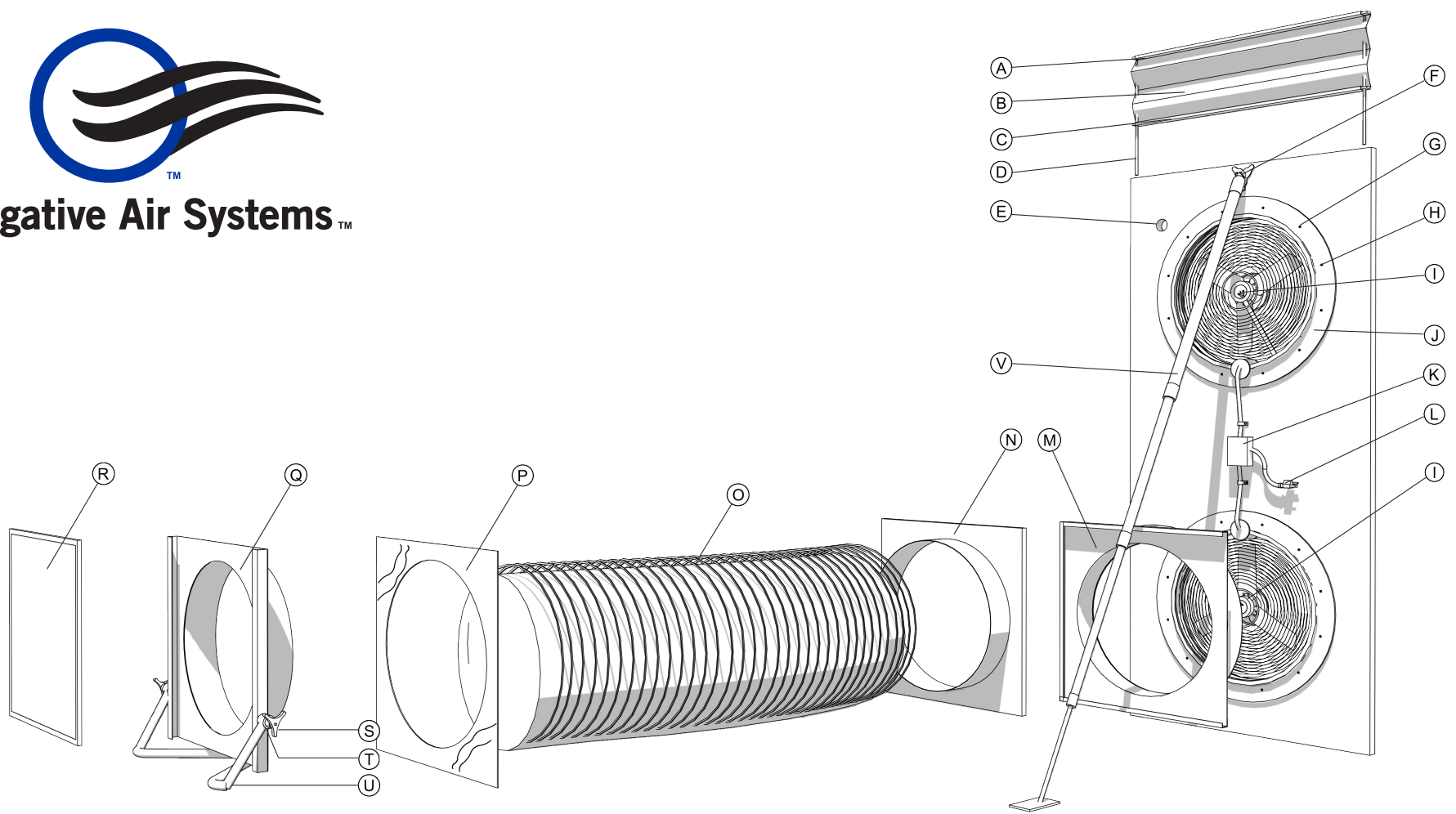

THE NEGATIVE AIR SYSTEM

COMPONENTS

- A:** Upper Stiffner Bar (28in, 32in, or 36in)
- B:** GSO Baffle ((28in, 32in, or 36in)
- C:** Lower Stiffner Bar (28in, 32in, or 36in)
- D:** Anodized Tension Rod
- E:** 60 mm Electrical Pass Through
- F:** Widget Cup
- G:** 1/4 x 20 Brass Rivet Insert
- H:** Sex Bolts
- I:** 20" 3-speed High Volume Fan
- J:** Blue HDPE 1/2 Collar
- K:** 3-way Sealed Junction Box
- L:** 110v Electrical PigTail
- M:** Filtered Panel Shroud
- N:** Flex Tube Adapter
- O:** Flex Tube
- P:** Flex Film
- Q:** Flex Tube Floor Shroud
- R:** 24" Reusable Filter
- S:** Floor Stand - Star Knob
- T:** Floor Stand - Nut, Bolt, Washer Assembly
- U:** Floor Stand
- V:** Adjustable Spring-Assisted Pole

RETURN POLICY

We at Negative Air Systems believe you will absolutely LOVE your Zephyr, Tempest, or Cyclone Dust Extractor, as well as ALL of the many Accessories we offer. But, if for some reason you want to return one of our products, please contact us (Negative Air Systems) DIRECTLY before you decide to return your product to the retailer. Our Customer Service Team can answer most of your questions and concerns. Give them a try!

Please contact us first: email us at: info@negairsys.com and put "CUSTOMER SERVICE" as the subject line, or contact us the via the old fashion way of Snail Mail:

Negative Air Systems
Attn: Customer Service
849 Pickens Industrial Dr., Ste 11
Marietta, GA 30062

The product must be returned in GOOD condition, in the original box, with ALL original Proof of Purchase, Parts, and Accessories, within the time frame specified by the retailer it was originally purchased from.

1 YEAR LIMITED WARRANTY STATEMENT FOR MANUFACTURE DEFECTS

Please read the Limited Warranty carefully. To maintain your warranty, you will need to comply with the conditions stated here. This warranty is for manufacturing defects ONLY and does not cover damages as a result of misuse or neglect.

1. Your 1 year limited warranty starts from the date of purchase. Please include a copy of the original receipt when contacting us at www.NegAirSys.com
2. Your new product comes with a 1 year warranty against manufacturing defects. This warranty starts on the date of purchase. No warranty will be honored without an ORIGINAL sales receipt. The warranty and financial responsibility of the manufacturer only applies to the product itself and does NOT extend to any other Entities or Items that may be affected directly or indirectly.
3. Manufacturing defects include circumstances where the product has broken under NORMAL use and no longer operates properly. In the event you encounter a manufacturing defect, please stop using the product immediately and contact Negative Air Systems Customer Service.
4. This warranty applies only when the product has been properly used by the consumer who originally purchased the product from authorized retailers as a NEW product. Proper use means:
 1. Properly securing the product before use
 2. Filtering/Cleaning dust and debris from electrical motors and switches
 3. Keeping electrical motors and switches dry and free from moisture
 4. Cleaning your Zephyr, Tempest, or Cyclone Dust Extractor between uses
5. If the product fails due to manufacturing defect, the manufacturer will repair or replace at its discretion. Negative Air Systems reserves the right to substitute comparable materials or models and does NOT guarantee the replacement part will match the existing piece or product
6. In the event the product needs to be inspected by the manufacturer to determine a warranty claim, the transportation cost is borne by the Customer